

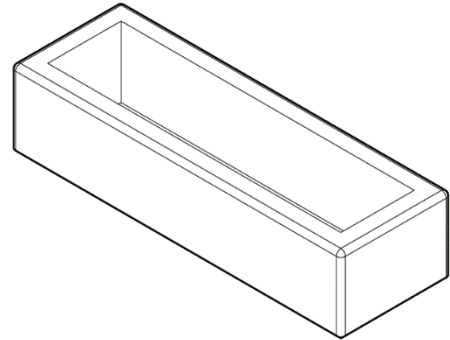

Product: Planter

Description:

Modular planter unit for the Bamburgh range, designed to be used in an arrangement or as a standalone unit. Precast concrete.
 Optional 2 x 30mm drain hole.
 Internal lifting points for installation or repositioning



Colour: Available in standard colours

- White: WH03, WH06
- Light Grey: LG01, LG02, LG05
- Dark Grey: BL02
- Black: BL03
- Buff: YL01
- Other colours available on request

Finish:

- Concrete: Light Acid Etched
- Timber: N/A
- Other finishes available on request

Fixing: Surface Fixed

Unit should be placed on finished surface, using appropriate lifting equipment, no additional fixing required.
 Optional fixing kit to secure the unit to foundation

Packing:

Banded & protected. 1 unit per pallet.
 Unit to be removed from the pallet before installation.

Standard Shipping:

Dedicated delivery or pallet service available by request

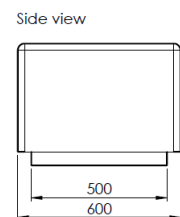
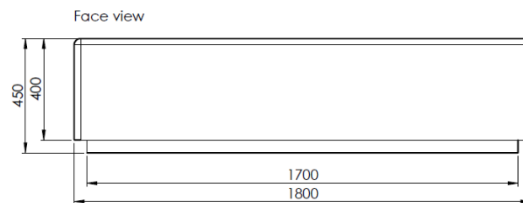
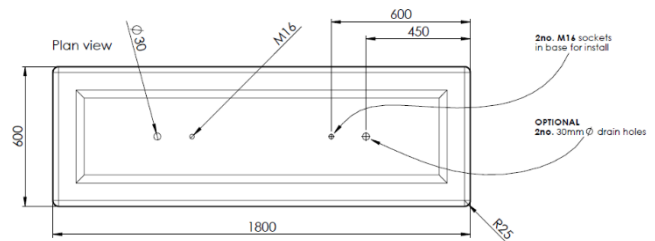

Technical Details:

- Length: 1800mm
- Depth: 600mm
- Height: 450mm
- Weight: 655Kg