



Product: Blanchland

Description:

Large planter, without base part of the Planter range, a standalone single unit. Precast concrete. Internal lifting sockets for installation

Colour: Available in standard colours

- White: WH03, WH06
- Light Grey: LG01, LG02, LG05
- Dark Grey: BL02
- Black: BL03
- Buff: YL01
- Other colours available on request

Finish:

- Concrete: Light Acid Etched
- Timber: N/A
- Other finishes available on request

Fixing: Surface Fixed

Unit should be placed on finished surface, using appropriate lifting equipment, no additional fixing required.

Optional fixing kit to secure the unit to foundation

Packing:

This unit requires site equipment with a hook and chains to offload, alternatively it could be delivered on a HI-Hab. Delivered on timber packers and supplied with appropriate, certified lifting loops

Standard Shipping:

Dedicated delivery.

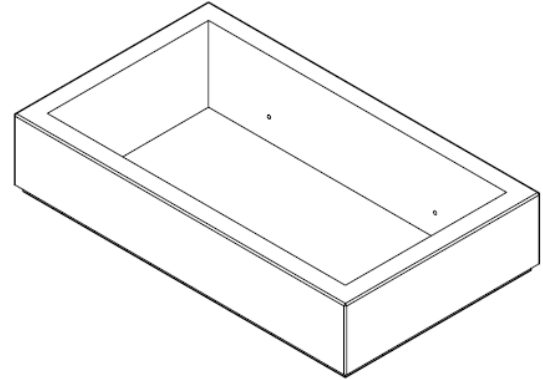

Plan view

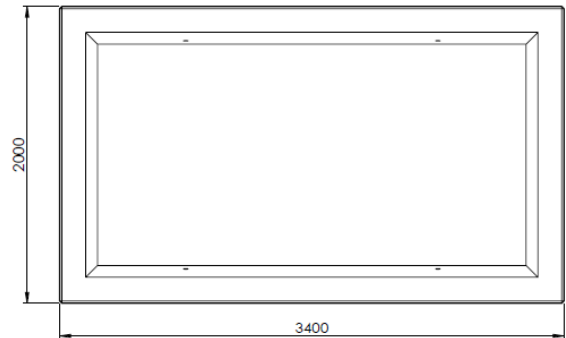

Face view

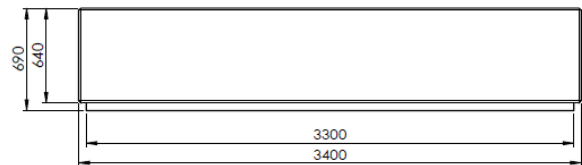

*15mm chamfer detail to all outside edges.

Technical Details:

- Length: 3400mm
- Depth: 2000mm
- Height: 690mm
- Weight: 3455Kg